

Real-Time PCR and Linkage Studies to Identify Carriers Presenting HPRT Deleted Gene

Cristina Lapucci,¹ Diego Pomarè Montin,¹ Massimo Pandolfo,² and Matteo Bertelli¹

¹Institute BIRD Europe, Vicenza, Italy; ²Department of Neurology, Erasme Hospital, Brussels Free University, Belgium

Lesch-Nyhan syndrome (LNS) is an X-linked genetic disorder resulting in hyperuricemia, choreoathetosis, mental retardation, and self-injurious behavior. It is caused by loss of activity of the ubiquitous enzyme hypoxanthine-guanine-phosphoribosyltransferase (HPRT). The biochemical analysis of residual HPRT activity in patients' red blood cells is the first step in LNS diagnosis, and it precedes molecular study to discover the specific mutation. Unfortunately, biochemical diagnosis of healthy carriers is difficult because HPRT enzymatic activity in blood cells is similar in LNS carriers and in healthy people; genetic tests can help reveal mutations at the genomic or cDNA level, whereas gross deletions involving the first or last exons of *HPRT* gene are not detectable. Until now, a test based on 6-thioguanine-resistant phenotype of HPRT mutant cells from LNS patients is the only method accepted for the diagnosis of any kind of mutation in carriers. In this work, we introduce a new approach to identify carriers of large deletions in HPRT gene using real-time PCR. Results were validated in a blinded manner with a linkage study and with results obtained in Italian families previously analyzed with selective medium test. Real-time PCR analysis clearly confirmed the results obtained by selective medium; linkage data strengthened real time results, allowing us to follow the allele with the mutated HPRT through the family pedigree. We hope that the real-time PCR approach will provide a useful and reliable method to diagnose LNS carriers of large deletions in *HPRT* gene.

Online address: <http://www.molmed.org>

doi: 10.2119/2005-00046.Lapucci

INTRODUCTION

Lesch-Nyhan syndrome (LNS) is a severe X-linked disease typically due to the absence of the ubiquitous enzyme hypoxanthine-guanine-phosphoribosyltransferase (HPRT). The clinical phenotype of male patients is characterized by hyperuricemia, learning difficulties, self-injurious behavior (SIB), choreoathetosis, and spasticity; the female carriers are usually healthy. So far, only 5 female carriers have presented a classic LNS phenotype, probably owing to a nonrandom inactivation of the X chromosome carrying the normal allele (1).

HPRT gene consists of 9 exons spanning approximately 44 kb at the Xq26 region and coding for a 219-aa protein that converts hypoxanthine into inosinic acid and guanine into guanylic acid. In the absence of HPRT, hypoxanthine is degraded into xanthine and uric acid in liver by xanthine oxidase (2).

The first step of LNS diagnosis is the biochemical analysis of residual HPRT activity in patients' erythrocytes; specific mutations are then discovered by molecular diagnosis by PCR analysis and direct sequencing of *HPRT* gene (3).

Diagnosis of a healthy carrier is difficult because HPRT enzyme activity in blood cells is similar in carriers and healthy people; genetic tests can help reveal mutations only when both alleles are amplified by PCR (from genomic DNA or cDNA), while gross deletions involving the ends of cDNA are not detectable by PCR (4).

So far, several approaches have been used to diagnose healthy carriers bearing large deletions. The first is based on DNA analysis by Southern blotting and linkage RFLP analysis (5,6). A second approach is based on mRNA analysis by amplification of HPRT cDNA. Samples from female carriers give rise to 2 PCR

products and both of them can be sequenced (7). These methods are insufficient to identify the deletion of the whole *HPRT* gene or deletions including its extremities. A third approach is based on a protein study such as the biochemical test of HPRT activity on hair bulbs (8); this biochemical/statistical approach was completely abandoned after the discovery of false-negative results (9). The last approach is based on a cell-growth test in a selective medium. O'Neill (10) developed a test in which only HPRT-deficient lymphocytes could grow in 6-thioguanine-enriched medium; the sensitivity and specificity of this test is about 99%. The method allows identification of carriers even if the mutation present in the patient's family is unknown, and it provides highly accurate results despite being technically and analytically demanding. Analysis requires a fresh blood sample and has to be performed by highly experienced personnel in diagnostic laboratories with the specific equipment for the cell γ -irradiation.

Here we introduce a new method to identify carriers with large deletion in

Address correspondence and reprint requests to Cristina Lapucci, c/o Institute BIRD Europe, Via Bizio 1, 36023 Longare (Vicenza), Italy. Phone: +390444555034; fax: +390444555557; e-mail: laboratorio@birdfoundation.org

Submitted June 16, 2006; accepted for publication July 29, 2006.

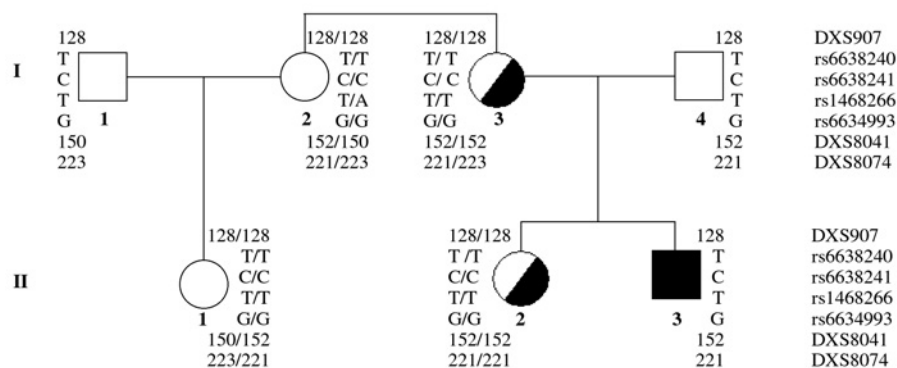

Figure 1. Family 1 pedigree and haplotype. Microsatellites and SNPs are listed in order of map position. II.3 is the proband, carrier of the deletion from exon 1 to 3 in *HPRT* gene. With the use of 3 microsatellite markers and 4 SNPs, the affected allele segregation can be followed; this affected allele is present only in the proband's sister and mother.

HPRT gene using semiquantitative real-time PCR, which has never been used before in the diagnosis of LNS. We validated the results with a linkage study.

Semiquantitative real-time PCR is a very powerful technique for deletion diagnosis and allows evaluation of the amount of target gene amplification by comparison with a reference gene using ΔC_t method (11), although the choice of appropriate conditions is fundamental to minimize artifacts due to nonspecific or primer-dimer products. Linkage study performed blindly with many heterozygous markers (12) differentiates one of the two maternal X-chromosomes carrying the mutated gene so that it may be followed through the family; linkage can be performed only if samples from members of all pedigrees can be collected (with particular exigency of proband and parent samples), and this is not always possible.

Our experiments were validated in a blinded manner, comparing results obtained by Italian families previously analyzed with approved diagnostic methods (i.e., O'Neill test). In this work, we propose semiquantitative real-time PCR as an alternative to the O'Neill test to diagnose carriers of large deletions in *HPRT* gene. Linkage study permitted us to further validate our method and provide stronger evidence of the reliability of this

approach. We can suppose that in the future, real-time PCR will provide a reliable method for LNS carrier identification.

MATERIALS AND METHODS

Families Study

We performed carrier diagnosis for 2 families already tested by O'Neill protocol in the selective medium. The first family is characterized by a deletion covering the region spanning exons 1 and 3 and comprises the proband, his sister, his

mother, his father, a female cousin, an aunt on the mother's side, and the aunt's husband (Figure 1). The second family presents the deletion of exon 9 and comprises 2 probands, their sister, their mother (father is deceased), a female cousin, an aunt on the mother's side, and the aunt's husband (Figure 2).

Blood samples were also collected from 50 healthy subjects deriving from many Italian regions to study the informativity of various markers used in the linkage study.

Genetic Study

To validate our approach, all the experiments were performed blind to the previous diagnosis obtained by selective medium growth. Moreover, real-time PCR results and linkage data were treated blindly.

Genomic DNA was extracted from blood by salting out (13). Real-time PCR was carried out in a 96-well optical reaction plate using an ABI Prism 7700 sequence detector (Applied Biosystems). PCR was performed in a 25- μ L reaction volume containing 2 \times SYBR Green PCR Master Mix (Applied Biosystems, USA), 300 nM forward and reverse primers, and 5 to 40 ng genomic DNA. PCR conditions were according to manufacturer's instructions. We chose only the border-

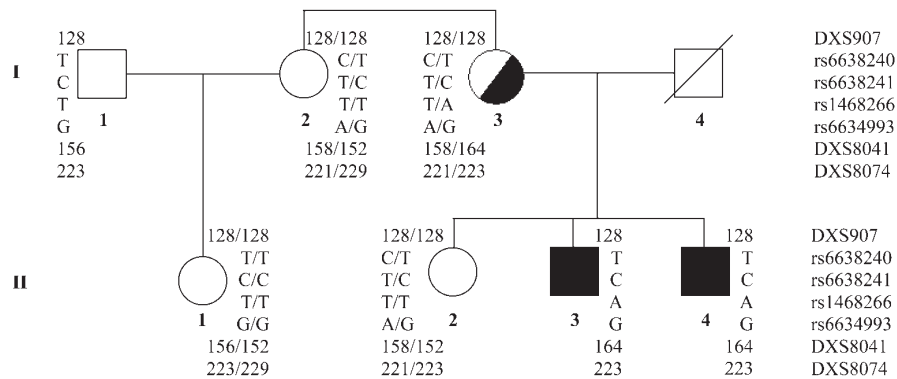

Figure 2. Family 2 pedigree and haplotype. Microsatellites and SNPs are listed in order of map position. II.3 and II.4 are the probands, carriers of deletion of *HPRT* exon 9. With the use of 3 microsatellite markers and 4 SNPs, the affected allele segregation can be followed; this affected allele is present only in the probands' mother.

Table 1. Features of microsatellites used in the linkage analysis

Microsatellite	Primers	Average heterozygosity	Distance from <i>HPRT</i> gene	Range of allelic size
DXS907	forward CAGTGTTTCAGTCTTCACCAGGAC reverse GCCCATGAATGAAATGAATGCC	0	~134 kb	127–140 bp
DXS8074	forward TTATAAATTAGCCAGAGGTGTG reverse CTAGGTGTCTGTAAAGGTAGG	0.60	~480 kb	221–231 bp
DXS8041	forward GCAAGACTCCGTCTCAAATAATAAC reverse TTCCTGCTACCTGCAATCC	0.36	~87 kb	144–164 bp

Average heterozygosity was calculated on 50 controls; distance between microsatellites and the middle of *HPRT* gene and size range of fragments were calculated by UCSC Genome Browser.

line area of *HPRT* gene to optimize this diagnostic protocol, in particular the region including exons 2 and 9. *FANCB* gene was chosen as genomic reference because it is localized on chromosome arm Xp but is far enough from *HPRT* not to be compromised by its deletions. Oligonucleotides were projected with Primer Express software (Applied Biosystems) and tested for specificity using NCBI's BLAST tool. Primer sequences of *HPRT* exon 2: forward 5'-GAA AGG GTG TTT ATT CCT CAT GGA-3', reverse 5'-GCT GCT GAT GTT TGA AAT TAA CAC A-3'; primer sequences of *HPRT* exon 9: forward 5'-GCT ATT CTT GCC TTT CAT TTC AGA A-3', reverse 5'-ACT CTC ATC TTA GGC TTT GTA TTT TGC-3'; primer sequences of *FANCB* exon 3: forward 5'-TGC AAT GAA GAT GAC TTA TTT GAA GA-3', reverse 5'-TCC TGT TTC TAG AGG TGG AAC CA-3'. In each assay, 5 normal controls and no-template controls were included. Each sample was run in triplicate, and each experiment was repeated 4 times. Standard curves for all primer pairs were performed using serial dilution of control DNA. *FANCB* standard curves: $y = -3.6574x + 23.539$; $R^2 = 0.9979$; *HPRT2* standard curves: $y = -3.2106x + 23.209$; $R^2 = 0.9955$; *HPRT9* standard curves: $y = -3.4714x + 22.325$; $R^2 = 0.9932$. The ΔC_t method was used to relatively quantify alleles in the analyzed region. This formula is based on the assumption that the rate changes of threshold cycle (C_t) are identical for *HPRT* and *FANCB* genes. Using this method, a control was normalized to value 1.

Bioinformatic analysis of chromosome region Xq26 near *HPRT* gene was performed with programs available on the web (UCSC genome Browser <http://genome.ucsc.edu>) and led to the identification of 3 dinucleotide microsatellites and 4 intragenic SNP markers for linkage analysis. The criteria used to select candidate markers were the maximum rate of heterozygosity cited and the minimum distance from the gene. Microsatellite PCR was performed in a 15-mL reaction volume containing 1.5 mM $MgCl_2$, 300 nM forward and reverse primers, 50 ng genomic DNA, and 0.8 units Taq Platinum Polymerase (Invitrogen). PCR conditions were 2 min at 95 °C, 35 cycles of 95 °C for 20 s, 53 °C (DXS8041 and DXS8074) or 60 °C (DXS907) for 15 s, and 72 °C for 20 s, and final extension at 72 °C for 10 min. Primers were projected with Primer Express software (Applied Biosystems) (Table 1). Amplification products were run with 0.5 μ L 500 ROX Standards (Applied Biosystems) on an ABI Prism

3130 DNA Sequencer (Applied Biosystems) and analyzed using GeneScan 3.1. Two of the 3 microsatellites were chosen according to their heterozygosity and their polymorphism (as described in UCSC Genome Browser). To confirm UCSC heterozygosity data, DXS907 and DXS8074 were tested in 50 control DNA samples. The unknown heterozygosity of microsatellite DXS8041 was tested in 50 control DNA samples.

The sequence of primers used to amplify SNP markers were derived from UCSC Genome Browser. The heterozygosity of SNP markers was analyzed by direct sequencing or by restriction fragment length polymorphism (RFLP) (Table 2). PCR for SNPs was performed in a 25-mL reaction volume containing 1.5 mM $MgCl_2$, 300 nM forward and reverse primers, 100 ng genomic DNA, and 1 unit Taq Platinum Polymerase (Invitrogen). PCR conditions consisted of an initial denaturation step of 2 min at 95 °C, followed by 35 cycles at 95 °C for

Table 2. Characteristics of SNPs used in linkage analysis

SNP	Restriction enzyme	Distance from exon 1 of <i>HPRT</i>	Average allele frequency	Average heterozygosity
rs6638241	—	~5 kb; in intron 1	C: 0.809 T: 0.191	0.219 \pm 0.248
rs6638240	—	~2 kb; in intron 1	C: 0.220 T: 0.780	0.219 \pm 0.248
rs1468266	<i>MseI</i>	~22 kb; in intron 3	A: 0.309 T: 0.691	0.406 \pm 0.195
rs6634993	<i>HaeIII</i>	~35 kb; in intron 6	G: 0.780 A: 0.220	0.219 \pm 0.248

Distance from *HPRT* exon 1 was calculated from UCSC Genome Browser map; average allele frequency and heterozygosity were obtained from NCBI database.

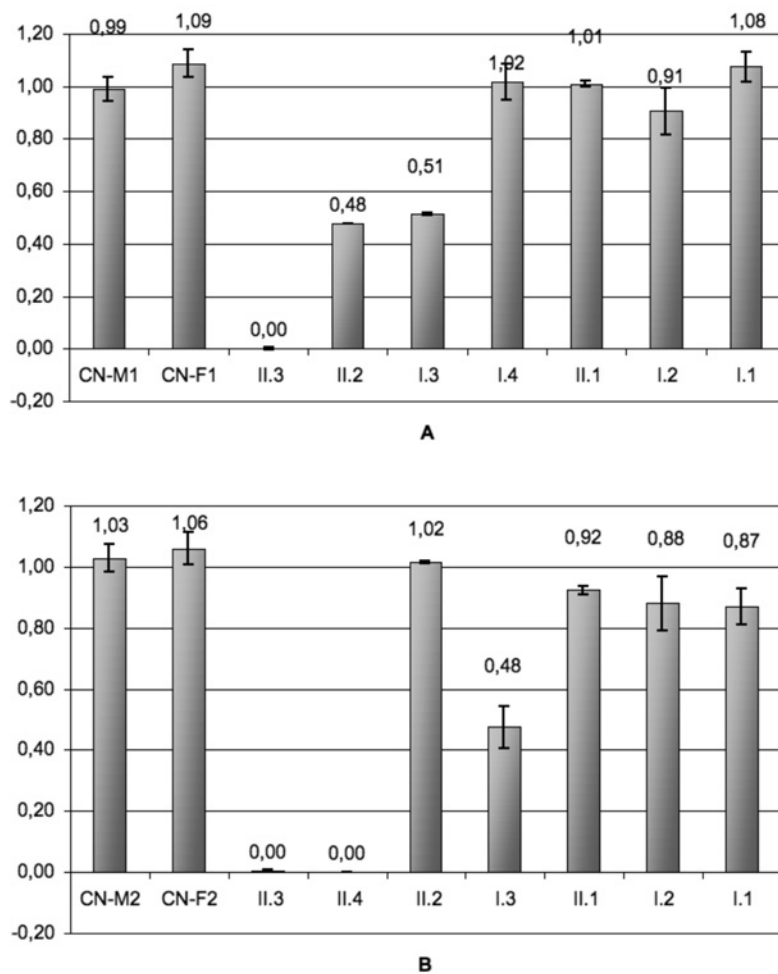

Figure 3. Semiquantitative real-time PCR results. Bars represent $2^{-\Delta C_t}$ value calculated by ΔC_t method. Data are normalized to a control DNA. Control samples were divided in male and female controls (CN-M and CN-F); each bar of male or female control is the result obtained by 3 different control patients. Male and female controls present the correct number of copies of *HPRT* in the region analyzed; on the other hand, LNS-positive controls (CP) present no copies of *HPRT*. (A) Real-time semiquantitative PCR results of *HPRT* exon 2 analysis. II.3 is the male proband, carrier of the deletion between exons 1 and 3; II.2 and I.3 are the proband's sister and mother, both carriers of the deletion; I.4 is the proband's father, showing a pattern similar to that of normal controls. On the mother's side, the female cousin, the aunt, and the aunt's husband (II.1, I.2, and I.1, respectively) show a pattern typical of nonaffected individuals. (B) Real-time semiquantitative PCR results of *HPRT* exon 9 analysis. II.3 and II.4 are the 2 affected brothers; II.2 is their sister, who presents a pattern similar to that of normal controls. I.3 is the proband's mother, who is a carrier of the deletion. The proband's relatives (the female cousin, the maternal aunt, and uncle by marriage, II.1, I.2, and I.1, respectively) show a normal pattern.

20 s, 56 °C for 15 s, and 72 °C for 20 s, and a final extension at 72 °C for 10 min. The amplified products were purified by GFX PCR DNA Purification Kit (Amersham Biosciences) and sequenced with BigDye

Terminator Kit v3.1 (Applied Biosystems). The products were purified with AutoSeq G50 (Amersham Biosciences) according to manufacturer's protocols. Sequences were analyzed by ABI Prism 3130 DNA

Sequencer (Applied Biosystems). RFLP analysis was performed by O/N enzymatic restriction digestion of products, according to manufacturer's protocols (Fermentas).

Following the segregation pattern of the maternal allele in the proband, we constructed the haplotype and subsequently analyzed each subject in the family.

RESULTS

Real-Time PCR

The first analysis was conducted in family 1 (Figure 3A). Family 1 carries an *HPRT* gene deletion between exons 1 and 3. Final standard deviation was calculated starting from single standard deviations obtained in each of the 4 experiments. Control samples were separated in male and female controls (CN-M1 and CN-F1) to show that, using *FANCB* gene as genomic reference, results were not influenced by gender. Each control bar is the result of 3 different control-patient results repeated in 4 experiments. The other bars represent values obtained from analysis of other family 1 members in all 4 experiments. In particular, II.3 is the male proband with deletion between exons 1 and 3; II.2 is his sister and shows a carrier pattern with heterozygous deletion of the same region. I.3 is the mother of the proband, carrier of deletion; I.4 is the father of proband, showing normal pattern. II.1 is a female cousin of the proband; I.2 is the maternal aunt of the proband and I.1 is the aunt's husband. All of proband's relatives showed a normal pattern (Figure 1).

The second experiment was done on family 2 (Figure 3B), which carries a deletion involving exon 9 of *HPRT* gene. We calculated a final single standard deviation from each test (repeated 4 times). Each control bar is the result of 3 different control-patient results repeated in 4 experiments as in the family 1 graphic. Control samples were separated in male and female controls (CN-M2 and CN-F2). The other bars represent values obtained from analysis of other members of family 1 in all 4 experiments. II.3 and II.4 are 2

Table 3. Real-time PCR results.

Samples	<i>n</i>	Mean	Range of value	SD of $2^{-\Delta\Delta C_t}$ <i>t</i> value
Negative male control	6	1.01	0.94–1.08	0.0449
Negative female control	6	1.07	1.00–1.14	0.0602
Positive control	3	0	—	—
Carrier	3	0.49	0.48–0.51	0.0173

Average value of the $2^{-\Delta\Delta C_t}$ is the result of each performed experiment. Results fluctuate in a small range of values. We show standard deviation as calculated for each sample in each experiment.

affected brothers; II.2 is their sister and is not a carrier for the deletion found in her brothers. I.3 is the mother of probands, carrier of deletion. No DNA sample from the father was available. II.1 is a female cousin of probands; I.2 is the maternal aunt of probands and I.1 is the aunt's husband. All probands' relatives showed a normal pattern (Figure 2).

All results of $2^{-\Delta\Delta C_t}$ were collected to calculate the mean value of each group of sample (male and female negative controls, positive controls, and carriers) and the fluctuation range of results (Table 3). Taken together, data shown in tables and standard deviation results confirm the reliability of real-time PCR results.

Microsatellite Analysis

We made haplotypes for each family using SNPs and microsatellite analysis. SNPs rs1468266 and rs6634993 are localized in corresponding sites of restriction, making it possible to perform a rapid discrimination by restriction enzyme. SNPs rs6638241 and rs6638240 were analyzed by direct sequencing. All 4 SNPs are in intronic regions of *HPRT* gene to warrant the lowest recombination frequency between marker and disease-allele (Table 2). The rate of heterozygosity of all SNPs permitted us to monitor affected *HPRT* pedigree transmission.

The fluorescent amplified fragment dinucleotide repeats are more informative than SNPs because of their heterogeneity among populations. None of them is intragenic, but we chose those located less than 1 centimorgan from *HPRT* gene to minimize recombination events (1 centimorgan corresponds to about 1 million

base pairs and to 1 recombination event between 2 loci in 1% of meioses observed). We could confirm the rate of heterozygosity for DXS8074, but we couldn't find any heterogeneity of DXS907. Data of heterozygosity for DXS8041 were calculated ex novo in 50 control subjects (Table 1), and 36% of tested females showed alleles with different sizes of these microsatellites.

In family 1, results show that the affected haplotype is not present in the proband's relatives; otherwise, both mother and sister of the proband carry the deletion.

In family 2, results show that the affected haplotype is not present in the probands' relatives; the mother of probands is a carrier only, and the sister is healthy. We were able to complete the investigation even though a biological sample from the probands' father wasn't available, and the results led to a correct and complete diagnosis.

DISCUSSION

LNS is a severe X-linked disease caused by hypoxanthine-guanine-phosphoribosyltransferase deficiency. To diagnose LNS, several approaches are possible, but the biochemical test on red blood cells still remains the preferred method. Females in LNS families are at risk of being carriers, and diagnosis is very important for their life expectations. Individuation of these carriers by biochemical diagnosis is difficult because *HPRT* activity in their red blood cells is similar to that in healthy people. New techniques in molecular biology can help to detect carriers only in the case that

both alleles are amplified by PCR. Gross deletions, particularly those involving the first exons and the last ones, are not detectable because the deleted allele can't be amplified on a genomic sample and PCR gives no results on cDNA. So far, a test based on 6-thioguanine-resistant phenotype of *HPRT* mutant cells from LNS patients is the only accepted method for diagnosis of carrier of any kind of mutation, but it is difficult to perform (10).

There have been reports in the literature that about 12% of American LNS cases are due to large deletions (14). Because there is no Italian population study of LNS patients, we used our cohort of patients to calculate the national incidence. In this work, we analyzed more than one fourth of all the Italian patients, partially already described (15), based on the specific international incidence (1/380,000) and the number of Italian population (6×10^7). Considering that 8 of 27 total families of our cohort have a large deletion, we may estimate that the national incidence of deletions in LNS patients is around 22.8% (calculated on mutation number instead of proband number, because affected brothers are collected).

Five of 8 families with deletion in *HPRT* gene could be of interest for this study, because their probands had deletions at the ends of *HPRT* gene. For only 2 of these families, the O'Neill test was available, so we used it to validate our approach. Carriers of 2 of the 3 remaining families that couldn't be studied by our approach were easily diagnosed with PCR multiplex protocol on cDNA (because their probands had deletions in exons 4 and 5); the proband of the third family carries a deletion in 5'UTR, so our primers weren't suitable, and PCR multiplex protocol couldn't be used.

The method proposed here is based on the use of semiquantitative real-time PCR to diagnose female carriers of *HPRT* deletion. We used samples from 2 families already tested by the O'Neill protocol (10) in a selective medium, but the previous results were unknown to the researchers and the experiments were performed blind.

In this study, real-time PCR was used to quantify the genomic copy number of the deleted region of HPRT gene. Because exon 1 is GC rich and also incompletely coding, we focused our analysis on exon 2 and exon 9. This protocol was optimized for deletion of these 2 regions of the gene, but it can be suitable for any type of deletion.

The first family analyzed had a deletion between exons 1 and 3. The selective medium test showed that the mother and sister of the proband are carriers of the mutation, whereas the aunt and the female cousin were not carriers. Family 2 had a deletion in exon 9. The selective medium test showed that only the mother of the probands is a carrier of the deletion. Real-time analysis (Figure 3) clearly confirmed results obtained by selective medium test. In fact, the mother and sister of the proband in family 1 and the mother of the probands in family 2 are the only carriers of respective deletions. Other members of the families have been found to have the expected normal amount of amplification product, and so they are healthy. The data is guaranteed by a number of negative controls (healthy controls) and by standard curves, repeated in each experiment, and confirmed in both control and carrier samples.

To validate the diagnostic pathway and results obtained by real-time PCR, we propose a haplotype analysis in blind. The pedigree analysis was optimized using data derived from the literature and from our laboratory experience. We chose 4 intragenic single nucleotide polymorphisms with high heterozygosity in the population. Moreover, we tested 3 dinucleotide microsatellites, close to HPRT gene, with high variability among the population. Results obtained with all these markers allowed us to make haplotypes for each family and revealed that there was no recombination between the 2 chromosomes in the region near HPRT gene. The haplotype analysis confirmed real-time PCR results, showing that the affected allele is present in female carriers and in male probands.

Methods based on real-time PCR can be used to evaluate gene deletion, although it must be taken in consideration that relative quantification requires stringent quality control and standardization of the sample acquisition and process, and that its reproducibility is inevitably compromised by the variable efficiency of the PCR itself. The exponential nature of PCR amplification means that small variations in reaction components and cycle conditions, besides mispriming events during the early stage of PCR, can greatly influence the final result. However, there is no doubt that real-time PCR is significantly less variable than any conventional quantification PCR procedure. On the other hand, linkage analysis also presents limitations. A single SNP or microsatellite is clearly insufficient for analysis, even if its heterozygosity is high. It is necessary to use several markers to ensure statistical efficacy. In these cases, clinical and familial context should be studied, and pedigree and heredity should be taken into account. Moreover, to give significant results, this method requires samples from many family members, and in the case of Lesch-Nyhan, samples from the proband and the mother are essential. Linkage analysis may strengthen diagnosis obtained by real-time PCR. Both techniques allow the use of DNA extracted from peripheral blood (fresh or frozen), making this procedure accessible to any laboratory. An approach based on both methods is clearly preferable to offer a reliable diagnosis, but we may suppose that in the future an accurate setting up of real-time PCR will permit the use of this technique alone for the LNS diagnosis. Based on our data, our new approach can be applied to 62.5% overall of the gross deletions, that is, the 22.8% of total LNS mutations.

In conclusion, we propose a new approach to diagnose LNS carriers that is suitable for a great part of LNS families with large deletions, as an alternative to the approved selective medium method, which is not always applicable.

ACKNOWLEDGMENTS

We are grateful to Paolo Gasparini, Leonarda Ianzano, and Paola de Gemmis for helpful discussion and critical revision of the manuscript.

REFERENCES

1. Nyhan WL (1972) Clinical features of the Lesch-Nyhan syndrome. *Arch. Intern. Med.* 130:186-92.
2. Nyhan WL (2005) Lesch-Nyhan disease. *J. Hist. Neurosci.* 14:1-10.
3. Page T, Bakay B, Nissinen E, Nyhan WL (1981) Hypoxanthine-guanine phosphoribosyltransferase variants: correlation of clinical phenotype with enzyme activity. *J. Inherit. Metab. Dis.* 4:203-6.
4. Gibbs RA, Nguyen PN, Edwards A, Civitello AB, Caskey CT (1990) Multiplex DNA deletion detection and exon sequencing of the hypoxanthine phosphoribosyltransferase gene in Lesch-Nyhan families. *Genomics* 7:235-44.
5. Nussbaum RL, Crowder WE, Nyhan WL, Caskey CT (1983) A three-allele restriction-fragment-length polymorphism at the hypoxanthine phosphoribosyltransferase locus in man. *Proc. Natl. Acad. Sci. U. S. A.* 80:4035-9.
6. Ogasawara N., Stout JT, Goto H, Sonta S, Matsumoto A, Caskey CT (1989) Molecular analysis of a female Lesch-Nyhan patient. *J. Clin. Invest.* 84:1024-7.
7. Daniels R, Adjaye J, Bolton V, Monk M (1998) Detection of a novel splice variant of the hypoxanthine-guanine phosphoribosyl transferase gene in human oocytes and preimplantation embryos: implications for a RT-PCR-based preimplantation diagnosis of Lesch-Nyhan syndrome. *Mol. Hum. Reprod.* 4:785-9.
8. Gartler SM, Scott RC, Goldstein JL, Campbell B (1971) Lesch-Nyhan syndrome: rapid detection of heterozygotes by use of hair follicles. *Science* 172:572-4.
9. Marcus S, Steen AM, Andersson B, Lambert B, Kristofferson U, Francke U (1992) Mutation analysis and prenatal diagnosis in a Lesch-Nyhan family showing non-random X-inactivation interfering with carrier detection tests. *Hum. Genet.* 89:395-400.
10. O'Neill JP (2004) Mutation carrier testing in Lesch-Nyhan syndrome families: HPRT mutant frequency and mutation analysis with peripheral blood T lymphocytes. *Genet. Test.* 8:51-64.
11. Ponchel F et al. (2003) Real-Time PCR based on SYBR-Green I fluorescence: an alternative to the TaqMan assay for a relative quantification of gene rearrangements, gene amplifications and micro gene deletions. *BMC Biotechnol.* 3:18.
12. Gibbs DA, Headhouse-Benson CM, Watts RW (1986) Family studies of the Lesch-Nyhan syndrome: the use of a restriction fragment length polymorphism (RFLP) closely linked to the disease gene for carrier state and prenatal diagnosis. *J. Inherit. Metab. Dis.* 9:45-57.
13. Miller SA, Dykes DD, Polesky HF (1988) A sim-

- ple salting out procedure for extracting DNA from human nucleated cells. *Nucleic Acids Res.* 16:1215.
14. Jinnah HA, De Gregorio L, Harris JC, Nyhan WL, O'Neill JP (2000) The spectrum of inherited mutations causing HPRT deficiency: 75 new cases and a review of 196 previously reported cases. *Mutat. Res.* 463:309-26.
 15. Bertelli M et al. (2004) Molecular basis of hypoxanthine-guanine phosphoribosyltransferase deficiency in Italian Lesch-Nyhan patients: identification of nine novel mutations. *J. Inherit. Metab. Dis.* 27:767-73.